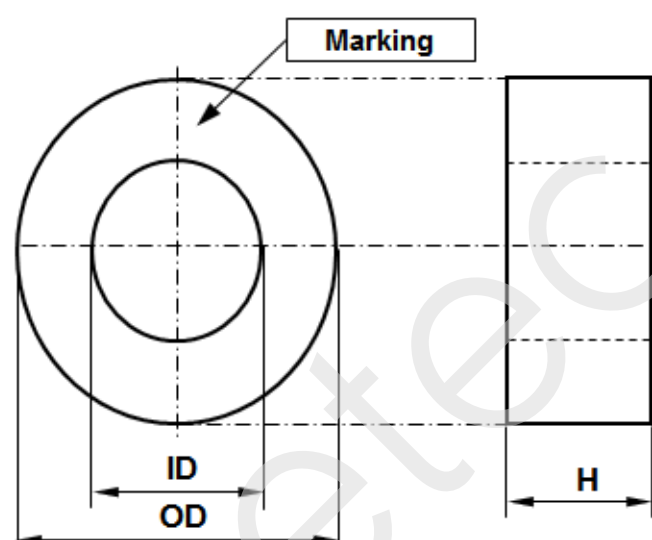

CONFIDENTIAL - Reproduction, publication and dissemination of this publication, enclosures hereto and the information contained therein is prohibited without MAGNETEC's prior written consent.

<b>Client:</b>	<b>MAGNETEC</b>	<b>Magnetec P/N:</b>	<b>M-148</b>		
<b>Client's P/N:</b>	/	<b>PS Index:</b>	<b>01</b>	<b>PS Revision:</b>	<b>01</b>
<b>Subject:</b>	<b>EMC Wandler</b>				

1. Mechanical Outline	
Nominal equivalent round core:  <b>90 x 60 x 20</b>  Finished product dimensions:  OD ≤ <b>94</b> ID ≥ <b>56</b> H ≤ <b>24</b>  [dimensions] = mm	

2. Core data (nominal values)			
Core material:	<b>NANOPERM®</b>	$L_{Fe} = 23,3 \text{ cm}$	$A_{Fe} = 2,19 \text{ cm}^2$
Permeability level:	<b>70 000</b>	@ frequency <b>10 kHz</b>	@ H peak <b>3 mA/cm</b>

3. Inspection values (at room temperature, unless otherwise stated)			
Measured value	Measurement limits	Frequency	$I_{eff} \times N$ [mA x turn]
<b>AL [μH]</b>	<b>58 - 116</b>	<b>10 kHz</b>	<b>49</b>
<b>AL [μH]</b>	<b>17,7 - NA</b>	<b>100 kHz</b>	<b>49</b>

4. Core finishing	
Type:	<b>Epoxy coated</b>
Marking:	<b>MAGNETEC M-148-01 YM (YM = Year/Month), acc. to IEC 60062 6.1.1</b>
Packaging:	<b>5 pcs. per layer; 3 layers per carton box; PU = 15 pcs.</b>

5. Comments
Visit <a href="http://www.magnetec.de/fileadmin/pdf/pb_ds.pdf">http://www.magnetec.de/fileadmin/pdf/pb_ds.pdf</a> for further information.

Index / Revision	Alteration	Date
01 / 01	First issue	18.07.2016

<b>Created:</b>	Z. Palánki 18.07.2016	<b>Approved (Techn):</b>	F. Záborszky 22.07.2016	<b>Approved (Quality):</b>	L. Ferencz 22.07.2016	<b>Released:</b>	T. Trupp 02.08.2016
-----------------	--------------------------	--------------------------	----------------------------	----------------------------	--------------------------	------------------	------------------------

CONFIDENTIAL - Reproduction, publication and dissemination of this publication, enclosures hereto and the information contained therein is prohibited without MAGNETEC's prior written consent. Disclosing the specification to third parties or using its content without written permission from MAGNETEC is strictly forbidden and every offender is liable to pay the corresponding damages.