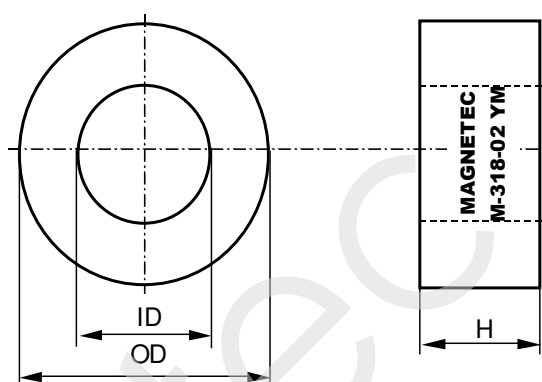

CONFIDENTIAL - Reproduction, publication and dissemination of this publication, enclosures hereto and the information contained therein is prohibited without MAGNETEC 's prior written consent.

Client:	MAGNETEC	Magnetec P/N:	M-318		
Client's P/N:	/	PS Index:	02	PS Revision:	02
Subject:	EMC Wandler				

1. Mechanical Outline	
Nominal equivalent round core: 10 x 7 x 6 Finished product dimensions: OD ≤ 12,0 ID ≥ 5,5 H ≤ 7,6 [dimensions] = mm	

2. Core data (nominal values)			
Core material:	NANOPERM®	$L_{Fe} = 2,64 \text{ cm}$	$A_{Fe} = 0,07 \text{ cm}^2$
Permeability level:	ca. 60 000	@ frequency 10 kHz	@ H peak 5,35 mA/cm

3. Inspection values (at room temperature, unless otherwise stated)			
Measured value	Measurement limits	Frequency	I _{eff} x N [mA x turn]
AL [μH]	13,5 - 27	10 kHz	10
AL [μH]	12 - 24	20 kHz	10
AL [μH]	4,9 - NA	100 kHz	10

4. Core finishing	
Type:	Epoxy coated
Marking:	MAGNETEC M-318-02 YM (YM = Year/Month), acc. to IEC 60062 6.1.1
Packaging:	600 pcs. per layer; 3 layers per carton box; PU = 1800 pcs.

5. Comments
Visit http://www.magnetec.de/fileadmin/pdf/pb_ds.pdf for further information.

Index / Revision	Alteration	Date
02 / 01	First issue	27.04.2006
02 / 02	Nominal permeability at 10kHz and AL limits at 10 and 100kHz are	14.05.2015

Created:	Z. Palánki 14.05.2015	Approved (Techn):	F. Záborszky 03.06.2015	Approved (Quality):	J. Gulyás 03.06.2015	Released:	T. Trupp 03.06.2015
-----------------	--------------------------	--------------------------	----------------------------	----------------------------	-------------------------	------------------	------------------------

CONFIDENTIAL - Reproduction, publication and dissemination of this publication, enclosures hereto and the information contained therein is prohibited without MAGNETEC's prior written consent. Disclosing the specification to third parties or using its content without written permission from MAGNETEC is strictly forbidden and every offender is liable to pay the corresponding damages.