

FORM Identifier: F 190 Revision: 02 Page: 1/1	Product specification for Inductive Components	MAGNETEC GmbH Industriestrasse 7 D-63505 Langenselbold
--	---	---

Client: Magnetec	Magnetec P/N: MB-654	Magnetec A/N: 84248
Client's p/n: /	PS Index: 01S	PS Revision: 01
Subject: EMC Component	Type:	

Preliminary datasheet : This document is strictly confidential ! It is subject to change without prior notice !

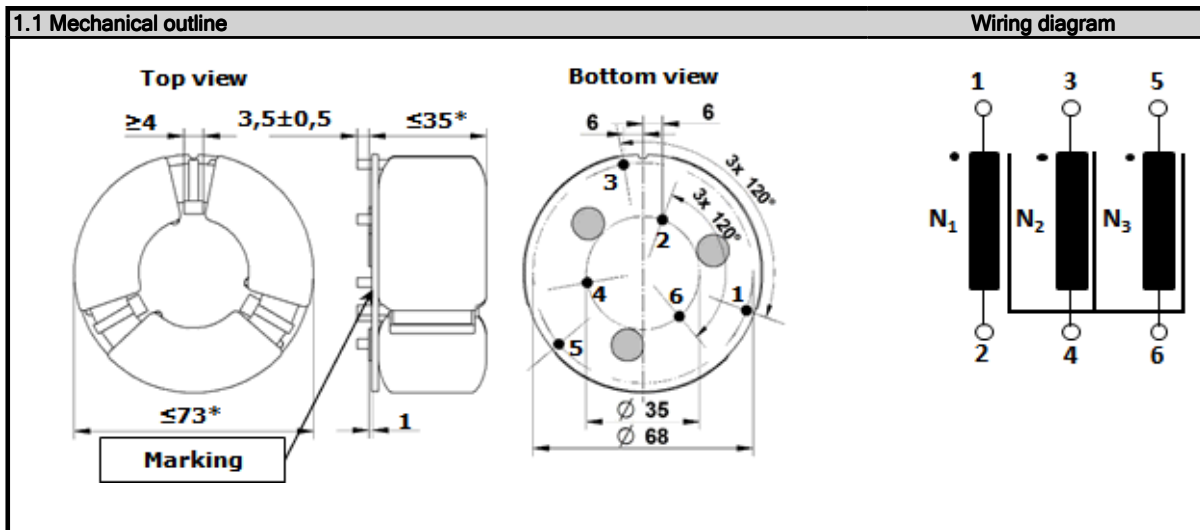

2. Nominal values			
Core material:	NANOPERM®	Wire Resistance:	≤ 2,8* mOhms
Nominal voltage:	440 Veff AC	High voltage strength:	Up,eff = 2,5 kV
Nominal inductance:	3 x 3 mH	Operating temperature:	-40 ... +70 °C
Nominal current:	27* A	Storage temperature:	-40 ... +85 °C
Leakage inductances:	? μH	Design standard:	EN 60938-1
No. of turns:	N1 = N2 = N3 = 12	Wire diameter:	3 mm
Comments:			

3. Inspection values			
	Measured value	Measuring limits	Measuring configurations
	Inductivity L 1; L2; L3 [mH]	1,9 - 4,2	f = 10 kHz Ueff = 0,1 V
	Inductivity L 1; L2; L3 [mH]	1,25* - NA	f = 100 kHz Ueff = 0,1 V
	Wire resistance Rcu 1; Rcu2; Rcu3 [mOhms]	0 - 2,8*	T = 23±3°C Ueff = 2,5 kV
	HV strength between N 1; N2 and N3	OK - NOK	t = 2 s
		-	

4. Others	
Marking:	MAGNETEC MB -654-01 YM SAMPLE (YM = Year/Month), acc. to IEC 60062 6.1.1
Packaging:	pcs. per layer, layers per carton box ; PU = pcs.
Comments:	* Needs to be verified during sample production.

Index / Rev.	Alteration	Date
01S / 01	Sample	28.01.2016

Created:	Z. Palánki	Approved (Techn):	Approved (Quality):	Released:
	28.01.2016			