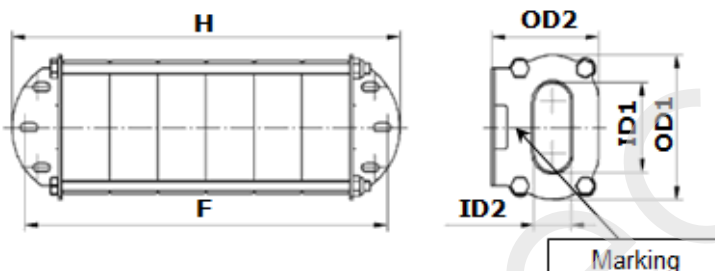

CONFIDENTIAL - Reproduction, publication and dissemination of this publication, enclosures hereto and the information contained therein is prohibited without MAGNETEC 's prior written consent.

<b>Client:</b>	<b>MAGNETEC</b>	<b>Magnetec P/N:</b>	<b>M-1628</b>		
<b>Client's P/N:</b>	/	<b>PS Index:</b>	<b>01</b>	<b>PS Revision:</b>	<b>01</b>
<b>Subject:</b>	<b>EMC Wandler</b>				

1. Mechanical Outline	
Nominal equivalent round core:  <b>80 x 63 x (30x6)</b>  Finished product dimensions:  OD ≤ ID ≥ H ≤  [dimensions] = mm  <b>OD1 = 110±0,5</b> <b>ID1 = 68±2</b> <b>OD2 = 82,5±0,5</b> <b>ID2 = 28±1</b> <b>F = 271±6</b> <b>H = 291±6</b>	

2. Core data (nominal values)			
Core material:	<b>NANOPERM®</b>	$L_{Fe} = 22,36 \text{ cm}$	$A_{Fe} = 11,16 \text{ cm}^2$
Permeability level:	/	@ frequency	@ H peak

3. Inspection values (at room temperature, unless otherwise stated)			
Measured value	Measurement limits	Frequency	leff x N [mA x turn]
<b>AL [µH]</b>	<b>144,6 - 289,2</b>	<b>10 kHz</b>	<b>50</b>
<b>AL [µH]</b>	<b>86,4 - NA</b>	<b>100 kHz</b>	<b>50</b>

4. Core finishing	
Type:	<b>Tube of cased cores</b>
Marking:	<b>See below</b>
Packaging:	<b>1 pcs. per layer; 1 layers per carton box; PU = 1 pcs.</b>

5. Comments
<b>LASER MARKING ON HOLDER :</b> <b>Data matrix MAGNETEC M -1628-01</b> Data matrix with the following content: <b>PYYWWD013009XXXXXX</b> (P=Plant code of MH YYWW= Year/Week D=Production day: 1=Monday / 2=Tue / 3=We / 4=Thu / 5=Fr / 6=Sa / 7=Sun XXXXXX= serial number) Visit <a href="http://www.magnetec.de/fileadmin/pdf/pb_ds.pdf">http://www.magnetec.de/fileadmin/pdf/pb_ds.pdf</a> for further information.

Index / Revision	Alteration	Date
01 / 01	Product Specification	15.09.2022

<b>Created:</b>	P. Kárpáti 15.09.2022	<b>Approved (Techn):</b>	Z. Makovinyi 01.06.2023	<b>Approved (Quality):</b>	D. Parragi 06.06.2023	<b>Released:</b>	B. Kessler 06.06.2023
-----------------	--------------------------	--------------------------	----------------------------	----------------------------	--------------------------	------------------	--------------------------

CONFIDENTIAL - Reproduction, publication and dissemination of this publication, enclosures hereto and the information contained therein is prohibited without MAGNETEC's prior written consent. Disclosing the specification to third parties or using its content without written permission from MAGNETEC is strictly forbidden and every offender is liable to pay the corresponding damages .